

# FT

n ≈ 2900 rpm



**Vertical inline pump**  
**Bomba vertical en-línea**  
**Pompe en ligne verticale**

### DESCRIPTION/DESCRIPCIONES/DESCRIPTION

- ◆ Single-stage centrifugal pumps in inline design
- ◆ With high temperature seal for using in heating systems
- ◆ YE3 high efficient motor, with protection IP55 class F
- ◆ Pump case with anti-corrosive coating
- ◆ Galvanized counter flange with bolts, nuts and gaskets
- ◆ Quality bearing, wear resistance mechanical seal
- ◆ Compact and proportional design

- ◆ Bombas centrífugas de una etapa en diseño en línea.
- ◆ Con cierre de alta temperatura para sistemas de calefacción
- ◆ Motor de alta eficiencia YE3, con protección IP55 clase F
- ◆ Caja de bomba con revestimiento anticorrosivo
- ◆ Contrabrida galvanizada con pernos, tuercas y juntas
- ◆ Rodamiento de calidad y cierre mecánico personalizado
- ◆ El diseño compacto y proporcional

- ◆ Pompes centrifuges à un étage de conceFtion en ligne
- ◆ Avec garniture haute température pour systèmes de chauffage
- ◆ Moteur haute efficacité YE3, avec protection IP55 classe F
- ◆ Boîtier de pompe avec revêtement anti-corrosif
- ◆ Contre-bride galvanisée avec boulons, écrous et joints
- ◆ Roulement qualité, joint mécanique de résistance à l'usure
- ◆ La conception compacte et proportionnelle

### USING LIMITS/LÍMITES UTILIZACIÓN/UTILISATION LIMITES

- ◆ Liquid temperature between -10°C and +120°C
- ◆ Ambient temperature between 0°C and +50°C
- ◆ Max. working pressure 16 bar/Continuous S1

- ◆ Temperatura del líquido de -10 °C hasta +120 °C
- ◆ Temperatura ambiente de 0 °C hasta +50 °C
- ◆ Presión máxima 16 bar/Continuo S1

- ◆ Température du liquide entre -10 °C et +120 °C
- ◆ Température ambiante entre 0 °C et +50 °C
- ◆ Max. pression de service 16 bar/Continu S1

### MODEL CODE/CÓDIGO MODELO/CODE MODÈLE

For example/Par ejemplo/Par exemple

**FT (m) 65 - 400 / 75**

75=Rated power(kw)x10  
 Potencia nominal(kw)x10  
 Puissance nominale (kw) x10

400=Nominal impeller size(mm)  
 Tamaño nominal del impulsor (mm)  
 Taille nominale de la roue (mm)

65=Discharge size(mm)  
 Tamaño de descarga (mm)  
 Taille de décharge (mm)

m=Single phase/Monofásico/Monophasé  
 Blank=Three phase  
 Blanco=Trifásico  
 Blanc=Triphasé

FT=Vertical inline pump  
 Bomba vertical en-línea  
 Pompe en ligne verticale

# FANCY

### TECHNICAL DATA/DATOS TÉCNICOS/DONNÉES TECHNIQUES

50 Hz n≈2900 l/min

MODEL MODELO MODÈLE	DN	Power Potencia Puissance		Q=DELIVERY/CAUDAL/DÉBIT																			
		mm	kw	hp	H=Head/Altura/Hauteur(m)																		
					l/min 0	100	150	250	300	400	450	600	700	800	900	1200	1400	1500	1800	2000	2300	3000	3500
					m³/h 0	6	9	15	18	24	27	36	42	48	54	72	84	90	108	120	138	180	210
FT 50-170/7 ★	50x50	0.75	1	17.5	16.7	15	12	9	-	-	-	-	-	-	-	-	-	-	-	-	-	-	-
FT 50-220/11 ★	50x50	1.1	1.5	22	21	19.7	16.5	14.5	9	-	-	-	-	-	-	-	-	-	-	-	-	-	-
FT 50-250/15 ★	50x50	1.5	2	25.4	23.7	22.5	18.5	15.8	-	-	-	-	-	-	-	-	-	-	-	-	-	-	-
FT 50-310/22 ★	50x50	2.2	3	31	29.6	28.5	24.5	22	15	-	-	-	-	-	-	-	-	-	-	-	-	-	-
FT 50-350/30 ★	50x50	3	4	35	34.3	34	28	25.5	19	15	-	-	-	-	-	-	-	-	-	-	-	-	-
FT 50-410/40 ★	50x50	4	5.5	41	-	-	-	38.5	36.2	35	30	25	-	-	-	-	-	-	-	-	-	-	-
FT 50-460/55 ★	50x50	5.5	7.5	46	-	-	-	43.8	41.3	40.1	35	30	-	-	-	-	-	-	-	-	-	-	-
FT 50-570/75 ★	50x50	7.5	10	57	-	-	-	53.6	51.5	50	45	41	36.5	-	-	-	-	-	-	-	-	-	-
FT 65-140/11	65x65	1.1	1.5	14.7	-	-	-	13.5	11.5	10.1	5.8	-	-	-	-	-	-	-	-	-	-	-	-
FT 65-180/15	65x65	1.5	2	18.1	-	-	-	17	15	13.9	9.6	6	-	-	-	-	-	-	-	-	-	-	-
FT 65-240/22	65x65	2.2	3	24.5	-	-	-	23.2	21.5	20.2	16	13	8.3	-	-	-	-	-	-	-	-	-	-
FT 65-310/30	65x65	3	4	31.8	-	-	-	29.5	27.5	26.3	21.5	17.5	-	-	-	-	-	-	-	-	-	-	-
FT 65-380/40	65x65	4	5.5	38	-	-	-	36	34	33	28.5	25	20.1	-	-	-	-	-	-	-	-	-	-
FT 65-320/55	65x65	5.5	7.5	32	-	-	-	-	-	-	30.6	30	28	26.6	20.5	14.8	-	-	-	-	-	-	-
FT 65-400/75	65x65	7.5	10	40	-	-	-	-	-	-	38	37	36	34.4	29	24	21	-	-	-	-	-	-
FT 80-190/40	80x80	4	5.5	19	-	-	-	-	-	-	-	-	17.3	16.8	14.5	13	11.8	-	-	-	-	-	-
FT 80-230/55	80x80	5.5	7.5	23	-	-	-	-	-	-	-	-	21.3	20.9	19	17.5	16.7	13.7	-	-	-	-	-
FT 80-270/75	80x80	7.5	10	27	-	-	-	-	-	-	-	-	26	25.6	24.5	23	22.5	20	18	-	-	-	-
FT 80-330/92	80x80	9.2	12.5	33	-	-	-	-	-	-	-	-	-	-	31.5	30	28	27.1	24	21.5	-	-	-
FT 80-360/110	80x80	11	15	36	-	-	-	-	-	-	-	-	-	-	34.5	33	31.5	30.8	28	25.5	-	-	-
FT 80-420/150	80x80	15	20	42	-	-	-	-	-	-	-	-	-	-	41	40	38.5	37.8	35	33	29.5	-	-
FT 100-270/110	100x100	11	15	27	-	-	-	-	-	-	-	-	-	-	-	-	-	27.3	26	24.5	22.5	16	-
FT 100-320/150	100x100	15	20	32.8	-	-	-	-	-	-	-	-	-	-	-	-	-	32.5	31.3	30.2	28.5	22.1	16.7
FT 100-390/185	100x100	18.5	25	39	-	-	-	-	-	-	-	-	-	-	-	-	-	38	36.8	36.7	33.8	28.8	23.5
FT 100-480/220	100x100	22	30	48	-	-	-	-	-	-	-	-	-	-	-	-	-	47.5	45.5	43.5	41	32.5	24.5
FT 100-600/300	100x100	30	40	60	-	-	-	-	-	-	-	-	-	-	-	-	-	59.5	58	57	54.5	47	40.5

★ =Cast iron impeller/Impulsor en fundición/Roue en fonte

### PERFORMANCE CURVE/CURVA DE RENDIMIENTO/COURBE DE PERFORMANCE

50 Hz n≈2900 l/min

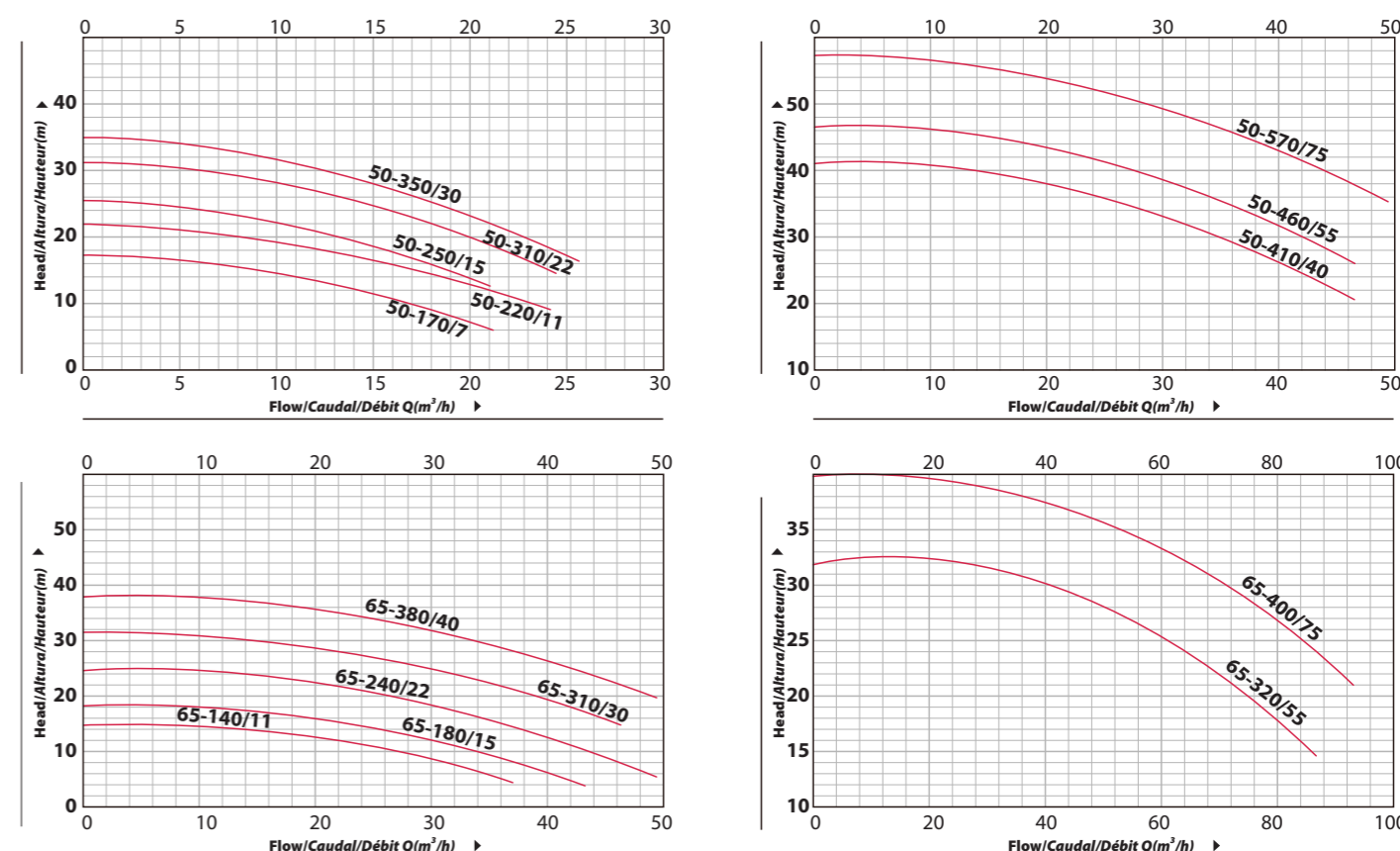

## PERFORMANCE CURVE/CURVA DE RENDIMIENTO/COURBE DE PERFORMANCE

50 Hz n≈2900 l/min

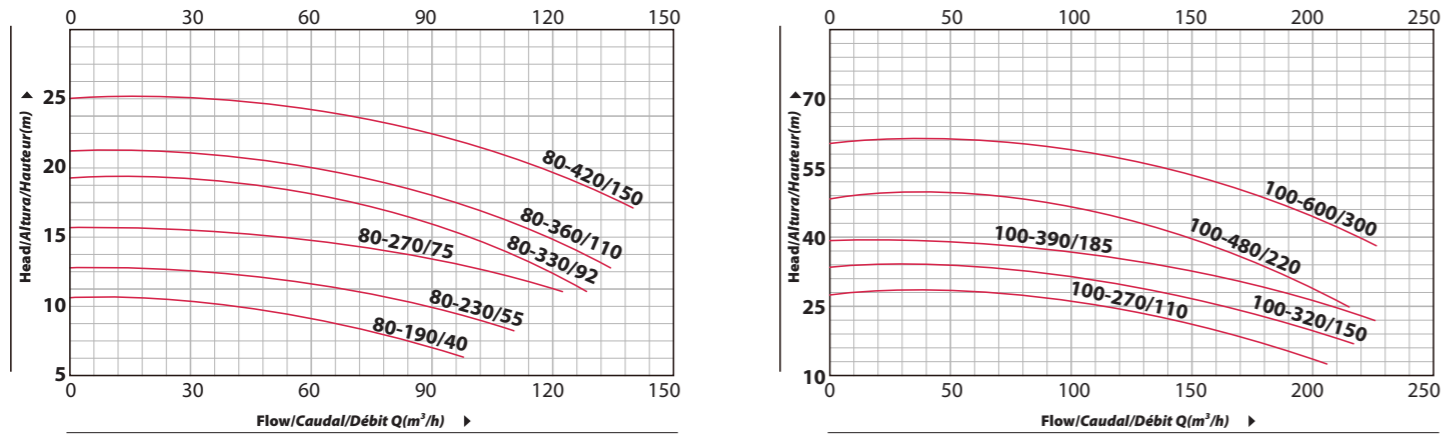

## MATERIAL DESCRIPTION/DESCRIPCIÓN DE MATERIAL/DESCRIPTION DU MATÉRIEL

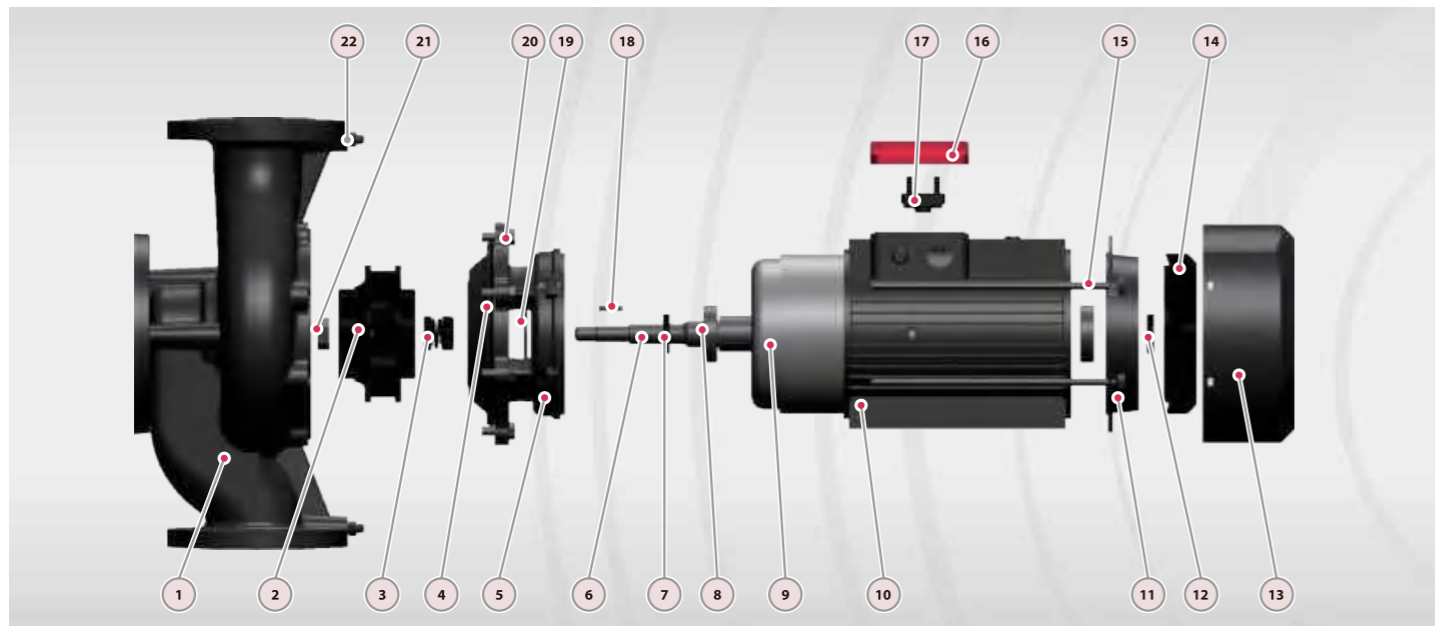

No.	Description Descripción Description	Material Material Matériel	No.	Description Descripción Description	Material Material Matériel	No.	Description Descripción Description	Material Material Matériel
1	Pump Case Cuerpo de Bomba Boîtier de pompe	Cast iron Fundición Fonte	9	Wound Stator/Rotor Estator/Rotor Stator/Rotor	Silicon Steel/Copper Silicio/Cobre Silicium/Cuivre	17	Terminal Board Tablero Bornas Bornier	Plastic Plástico Plastique
2	Impeller Impulsor Roue	SS304/Cast iron Inox 304/Fundición Inox 304/Fonte	10	Motor Case Cuerpo Motor Boîtier Moteur	Aluminum Aluminio Aluminium	18	Impeller Key Chaveta Clé	Iron Hierro Le fer
3	Mechanical Seal Cierre Mecánico Sceller	SiC/Carbon/SS304 SiC/Grafito/Inox304 SiC/Carbon/Inox304	11	Back Cover Tapa Trasera Capot Arrière	Cast iron Fundición Fonte	19	Water Deflector Deflector Déflecteur	Rubber Caucho Caoutchouc
4	O-ring Junta Tórica Joint Torique	Rubber Caucho Caoutchouc	12	Reinforced Seal Sello Reforzado Sceller	Rubber Caucho Caoutchouc	20	Connection Bolt Perno Boulon de connexion	Steel Acero Acier
5	Connection Conexión Lien	Cast iron Fundición Fonte	13	Fan Cover Tapa Capot	Aluminum Aluminio Aluminium	21	Impeller Nut Nuez Noix	Galvanized Steel Acero Galvanizado Acier Galvanisé
6	Shaft Eje Arbre	SS304-45# Steel Inox 304-Hierro Inox304-Acier	14	Fan Ventilador Ventilateur	Plastic Plástico Plastique	22	Release Valve Tapón Cebado Soupape de décharge	Brass Bronce Laiton
7	Reinforced Seal Sello Reforzado Sceller	Rubber Caucho Caoutchouc	15	Through Bolt Perno Boulon	Steel Acero Acier			
8	Bearing Rodamiento Palier	Ball Bearing Bola Rodamiento Palier Balle	16	Terminal Box Caja Bornas Boite Bornes	Aluminum Aluminio Aluminium			

## DIMENSIONS AND N.W./DIMENSIONES Y PESOS/DIMENSIONS ET POIDS

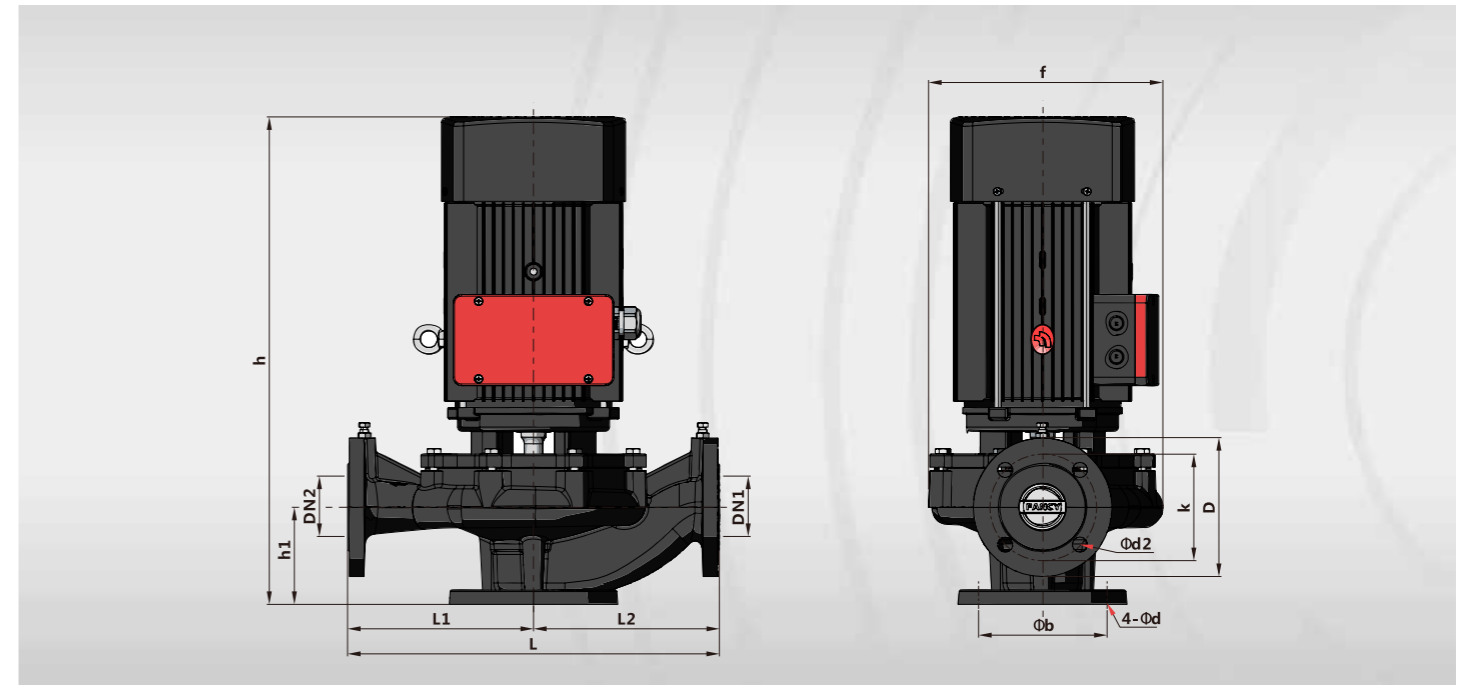

MODEL/MODELO/ MODÈLE	DIMENSIONS/DIMENSIONES/DIMENSIONS mm													kg	
	DN1	DN2	h	h1	L	b	f	d	L1	L2	D	K	d2	1-	3-
50-170/7	50	50	475	115	340	145	197	18	170	170	165	125	4*18	26	24
50-220/11	50	50	475	115	340	145	197	18	170	170	165	125	4*18	27	25
50-250/15	50	50	450	100	322	145	229	18	161	161	165	125	4*18	36	34
50-310/22	50	50	450	100	322	145	229	18	161	161	165	125	4*18	41	39
50-350/30	50	50	480	100	322	145	229	18	161	161	165	125	4*18	52	50
50-410/40	50	50	485	115	440	160	277	18	220	220	165	125	4*18	-	59
50-460/55	50	50	485	115	440	160	277	18	220	220	165	125	4*18	-	66
50-570/75	50	50	485	115	440	160	277	18	220	220	165	125	4*18	-	73
65-140/11	65	65	465	105	360	145	212	18	180	180	185	145	4*18	29	27
65-180/15	65	65	465	105	360	145	212	18	180	180	185	145	4*18	31	29
65-240/22	65	65	465	105	360	145	212	18	180	180	185	145	4*18	36	34
65-310/30	65	65	530	112	400	160	250	18	200	200	185	145	4*18	50	48
65-320/55	65	65	583	112	400	160	263	18	200	200	185	145	4*18	-	64
65-400/75	65	65	583	112	400	160	263	18	200	200	185	145	4*18	-	71
80-190/40	80	80	615	135	470	180	267	18	235	235	200	160	8*18	-	56
80-230/55	80	80	615	135	470	180	267	18	235	235	200	160	8*18	-	68
80-270/75	80	80	615	135	470	180	267	18	235	235	200	160	8*18	-	74
80-330/92	80	80	658	135	470	200	290	18	235	235	200	160	8*18	-	90
80-360/110	80	80	658	135	470	200	290	18	235	235	200	160	8*18	-	106
100-270/110	100	100	685	160	552	220	310	18	276	276	220	180	8*18	-	113
100-320/150	100	100	807	160	552	220	310	18	276	276	220	180	8*18	-	143
100-390/185	100	100	807	160	552	220	310	18	276	276	220	180	8*18	-	150
100-480/220	100	100	880	160	552	220	322	18	276	276	220	180	8*18	-	212
100-600/300	100	100	950	160	552	220	322	18	276	276	220	180	8*18	-	222