

FBZ

Energy saving smart circulation pump
Bomba circulación de ahorro energía
Pompe circulation économie d'énergie



FBZ-6



FBZ-8

DESCRIPTION/DESCRIPCIONES/DESCRIPTION

- The control panel allows one to select the preferred work curve by means of three programmes.
- El panel de control permite seleccionar la curva de trabajo preferida mediante tres programas.
- Le panneau commande permet sélectionner la courbe travail préférée au moyen de trois programmes.

	PP1-PP2-PP3 PROPORTIONAL PROGRAMME PROGRAMA PROPORCIONAL PROGRAMME PROPORTIONNEL	Pressure/delivery changes proportionally. Presión/entrega cambia proporcionalmente. Pression/débit modifie proportionnellement.
	CP1-CP2-CP3 CONSTANT PROGRAMME PROGRAMA CONSTANTE PROGRAMME CONSTANT	Pressure constant with variation of delivery. Presión constante con variación de entrega. Pression constante de variation du débit.
	I - II - III SPEED PROGRAMME PROGRAMA DE VELOCIDAD PROGRAMME DE VITESSE	Fixed speed curves of operation. Curvas de velocidad fija de funcionamiento. Courbes de fonctionnement à vitesse fixe.

DIMENSIONS AND WEIGHT/DIMENSIONES Y PESOS/DIMENSIONS ET POIDS

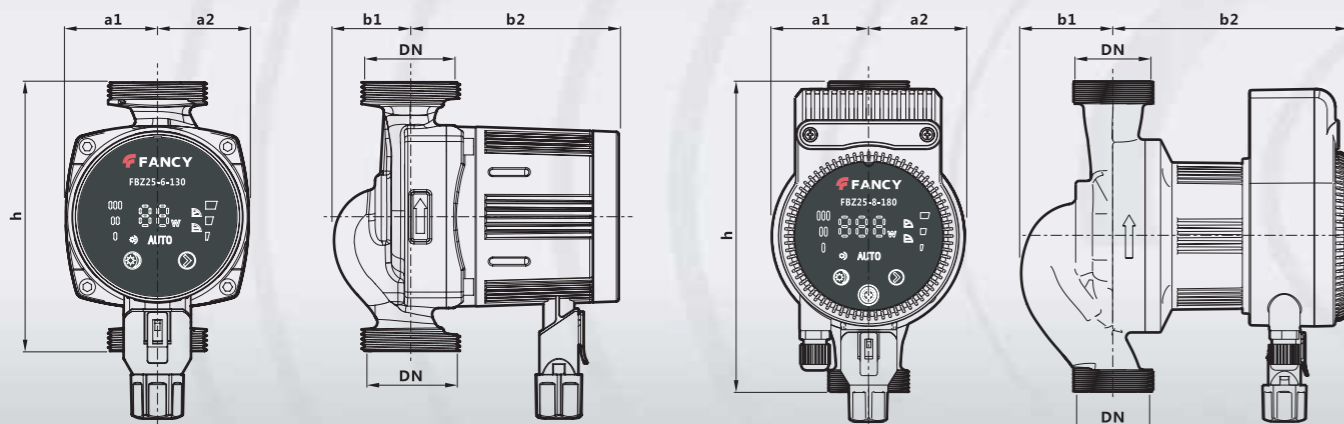

FANCY

TECHNICAL DATA/DATOS TÉCNICOS/DONNÉES TECHNIQUES

MODEL MODELO MODÈLE	Power	Voltage	Max flow	Max Head	DN	h	a1	a2	b1	b2
1-ph	W	V	m ³ /h	m	mm	mm	mm	mm	mm	mm
FBZ25-6-130	15-35	220V	3.1	6	40 to 25	130	44	44	35	103
FBZ25-6-180	15-35	220V	3.1	6	40 to 25	180	44	44	35	103
FBZ32-6-130	15-35	220V	3.1	6	50 to 32	130	44	44	35	103
FBZ32-6-180	15-35	220V	3.1	6	50 to 32	180	44	44	35	103
FBZ25-8-180	25-125	220V	8.3	9	40 to 25	180	56	56	54	135
FBZ32-8-180	25-125	220V	8.3	9	50 to 32	180	56	56	54	135

PERFORMANCE CURVE/CURVA DE RENDIMIENTO/COURBE DE PERFORMANCE

